

**CAUTION:**  
FAILURE TO FOLLOW THESE INSTRUCTIONS WILL VOID  
ALL WARRANTIES, EXPRESSED AND IMPLIED. EXTREME CAUTION MUST BE EXERCISED  
TO PREVENT SEVERE BODILY INJURY OR DEATH.

## Description

---

Warp Drive propellers are fixed-pitch and ground-adjustable.

All propeller components are manufactured in the USA by Warp Drive Inc. using materials sourced domestically. Proprietary processes ensure a unique high-quality product. All Warp Drive blades are solid carbon fiber. The blades are not hollow and do not contain a core of another type of material such as foam, honeycomb, wood, etc... Solid carbon fiber construction results in an extremely rigid and durable product.

All blades are painted with flat black lacquer which provides UV and environmental protection. This type of paint is utilized because it is readily available world-wide which allows repairs to be done by the end-user which drastically reduces cost-of-ownership.

The optional inlaid nickel leading-edge protects against rain, ice, sand or other highly abrasive environments.

The optional tapered blade upgrade reduces blade area which allows for a higher blade-pitch resulting in increased cruise performance.

The typical usable blade pitch angle range is 6 degrees to 18 degrees. The recommended pitch of the propeller depends on the intended speed of the vehicle, powerplant specifications, propeller diameter, and propeller options.

All blades and H-series hubs have laser engraved serial numbers for traceability. Please note that serial numbers are different from the model numbers shown in the chart below.

Model numbers are based on the assembled-diameter, rotation, options, number of blades and hub type. The rotation is left-hand (L) or right-hand (R). The designation for the options are as follows: W or N=Nickel leading-edge option, T=Tapered tip option.

| Model#      | Dia (in) | Rotation   | Options        | Hub Model | Blade Qty |
|-------------|----------|------------|----------------|-----------|-----------|
| 72R-NX-HPL2 | 72       | Right-hand | Nickel only    | HPL       | 2         |
| 70L-XX-HP2  | 70       | Left-hand  | None           | HP        | 2         |
| 69L-NT-HX4  | 69       | Left-hand  | Nickel & Taper | Standard  | 4         |
| 68R-XT-H4   | 68       | Right-hand | Taper Only     | H         | 4         |
| 64R-XT-HPL3 | 64       | Right-hand | Taper only     | HPL       | 3         |

## Inventory

---

Items included with complete propellers:

| Included Components                       | Quantity |
|---|----------|
| H4 Hub Half (H4-00-xx) Larger Centerhole  | 1        |
| H4 Hub Half (H4-01-xx) Smaller Centerhole | 1        |
| Solid Carbon Fiber Propeller Blade        | 4        |
| 0.25-in Clamping Bolt (AN4-20A)           | 16       |
| 0.25-in Clamping Nyloc Nut                | 16       |
| 0.25-in Clamping Washer                   | 32       |
| Warp Drive Protractor                     | 1        |
| Stoneguard Leading-edge Tape              | 4        |

Items required but not included with complete propellers:

| Components Sold Separately  | Quantity |
|---|----------|
| Mounting Bolts & Washers (Nuts optional depending on configuration) | 6        |
| Faceplate / "Crushplate" (Thickness ~ 0.25-in)                      | 1        |

### FACEPLATE NOTICE:

A faceplate is required.

| Faceplate Thickness | Mounting-Bolt Size | Comment   |
|---------------------|--------------------|---|
| 1/4-in (6.350mm)    | M8                 | 1/4-in bolts are possible.<br>5/16-in bolts fit in 8mm holes. |

Drawings

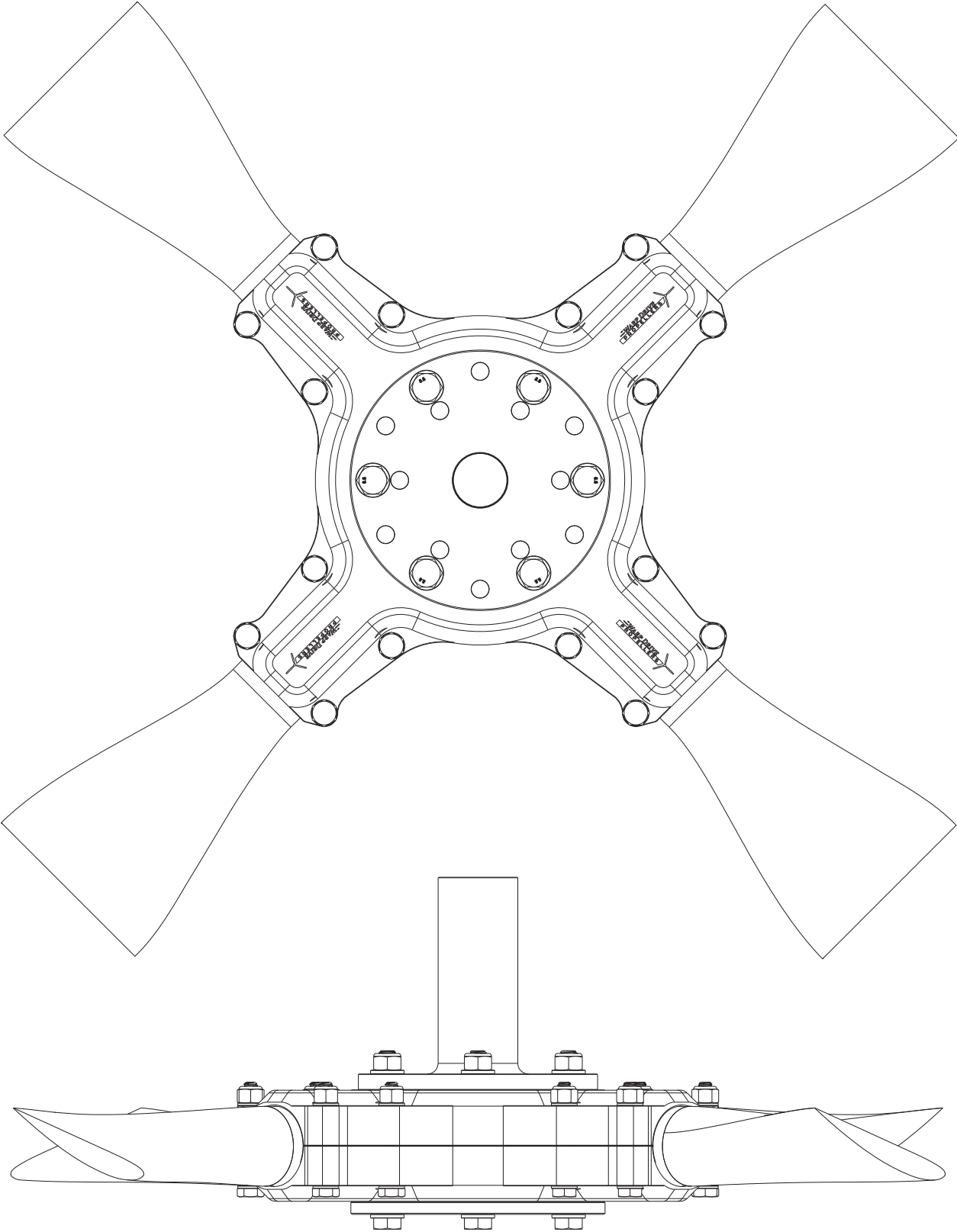

## Propeller Assembly

---

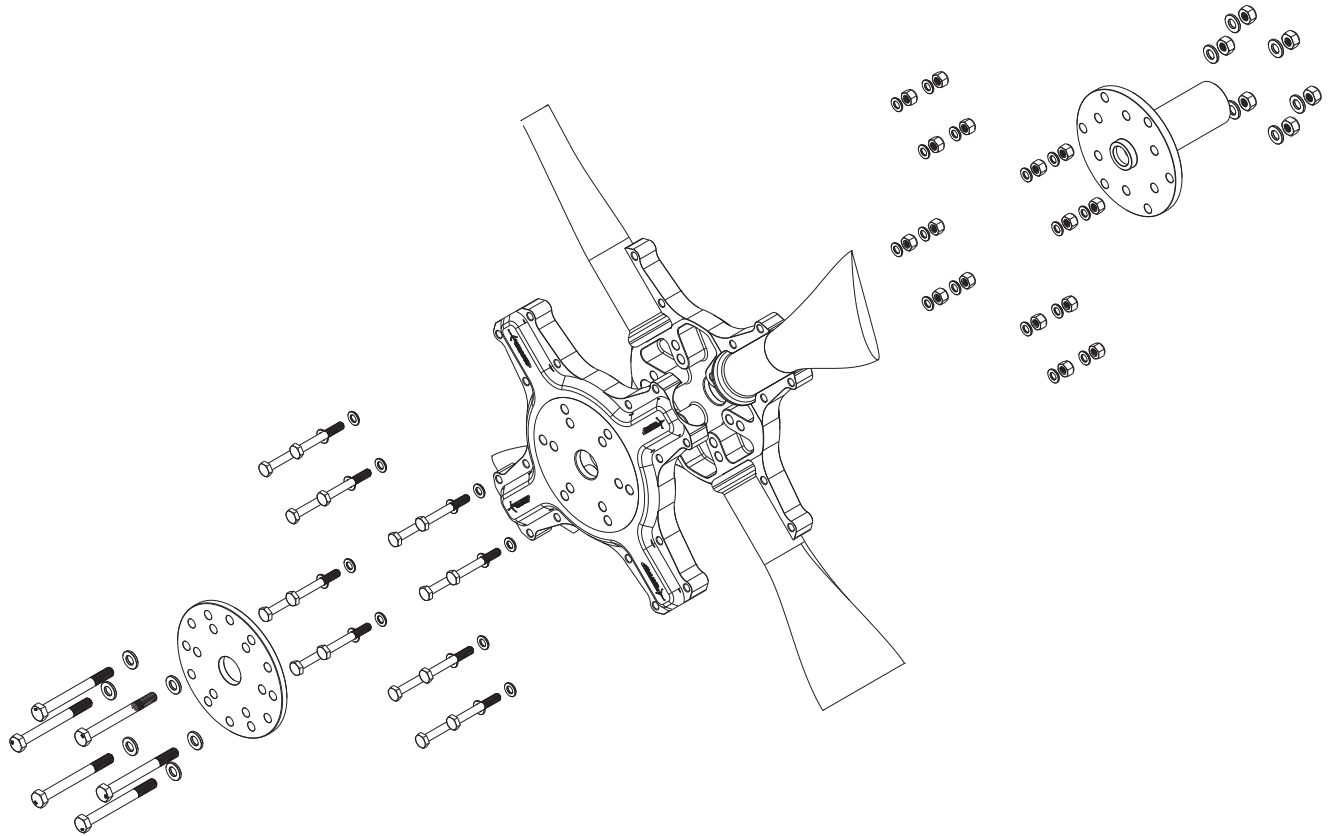

Assemble the propeller as shown in the diagram above.

NOTE: The two hub halves contain different sized centerholes. Part numbers are engraved internally on both hub pieces. The part numbers are:

H4-00-xx = LARGER Centerhole

H4-01-xx = SMALLER Centerhole

### **Use the hub half which best fits with your propeller flange.**

Across various engine manufacturers, and even within the same engine/gearbox model over time, there is variation in the size of the “1-in” centering-boss on the propeller-flange. Variation in the hub-centerhole diameter is intentional to provide fitment flexibility.

Ensure the flange centering-boss is free of corrosion, burrs, damage. Install the hub half against the gearbox flange with the tightest fit, without needing to be “pressed” or “pulled” on.

## Propeller Assembly

---

Calibrated torque wrench required.

- Only partially tighten nuts/bolts when first mounting the propeller. The blades must be able to rotate in the hub to set the blade pitch.
- The 0.25-in blade-clamping-bolts may face either direction (forward or backward). It is proper to use a torque wrench on the clamping nut, NOT the head of the bolt. Therefore, orient the bolts to allow easy access to the nuts with a torque wrench.
- The six propeller-mounting-bolts will either have drilled-heads to facilitate safety wire OR they will be secured with a Nyloc nut. The proper method of installing bolt safety-wire is beyond the scope of this manual.
- Loctite is not sufficient for securing hardware.

### Choosing a Bolt Pattern to Use

Some gearbox flanges contain both a 75mm and 100mm bolt pattern.

- If you have greater than 95HP, use the 100mm pattern.
- If you have less than 95HP, use either pattern.
- Consider your opinion on “jam nutting.” If your propeller flange has threaded holes on one pattern and not the other, you might choose which one to use based on which method you prefer to use to secure the six mounting-bolts. If you wish to use drilled-head bolts which are secured with safety wire then you must use a pattern with threaded holes in the gearbox flange. When using safety-wire, the installation of a nut on the threads of the bolt is not required. If you wish to secure the bolts with Nyloc nuts instead of safety wire, then you can decide whether to use a bolt pattern with threaded holes or not. If you install a non-drilled-head bolt into a threaded hole on the gearbox flange you MUST install a Nyloc nut on the bolt and torque the nut against the gearbox flange to “jam nut” it. When jam nutting you must torque the bolt to the correct torque spec AND then the nut. YOU MUST also ensure that the mounting-bolts aren’t too long, which would result in the bolt “bottoming out” before compressing the propeller assembly.

Do NOT torque the bolts to final torque at this time.  
The final assembly is described in the next section of this manual.

| Bolt Size | Torque Specification |       |       | Bolt Type |
|-----------|----------------------|-------|-------|-----------|
|           | ft-lb                | in-lb | Nm    |           |
| M8x1.25   | 15                   | 180   | 20.4  | Mounting  |
| 1/4-in    | 10                   | 120   | 13.56 | Clamping  |

## Starting Assumptions

1. You have used our Propeller Assembly Instructions or a Propeller Manual to mount your propeller to your engine/gearbox with the propeller-mounting-bolts and blade-clamping-bolts loose enough to allow the blades to still rotate in the hub.
2. You have standard hand tools and are using a **calibrated torque wrench**.

## Protractor Description

Outer Scale: Located on the main body of the protractor (gray). Marked in  $1^\circ$  increments.

Inner Scale: Located on the movable inner wheel (white). Marked in 5 second increments.

White Clamp: Contacts the curved-side of the blade when the Wing Nuts are tightened.

- The white clamp is designed to bend as you tighten the wing nuts.

Lock Knob: Can be tightened to prevent the inner wheel from rotating.

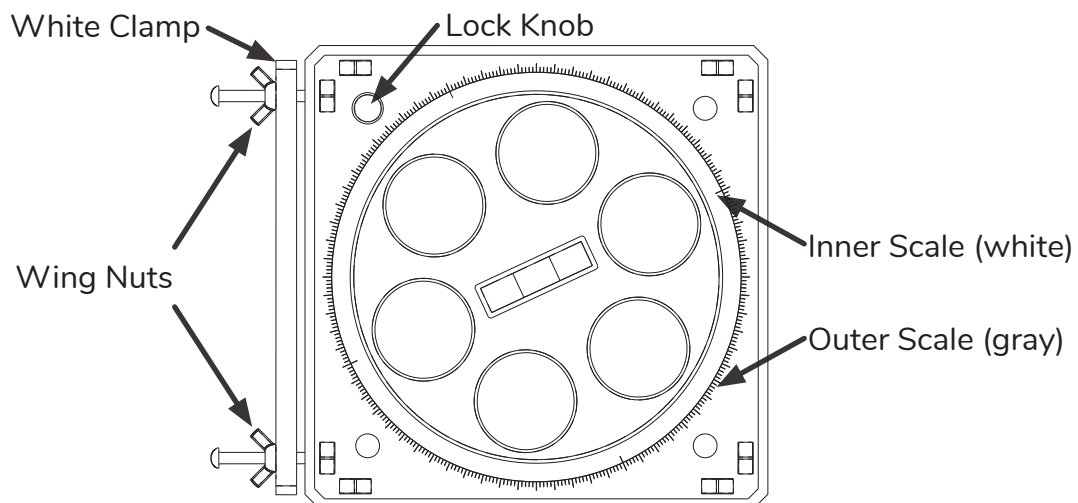

Figure A: Protractor

## How Warp Drive References Pitch

The pitch of a Warp Drive propeller is referenced in degrees.

Pitch (degrees) = The difference between the hub angle and the blade tip angle.

## Terminology

The tips of two different propeller blades are shown in Figure B below, the one on the left is for a left-hand rotation propeller and the one on the right is for a right-hand rotation propeller. Look at the tip of one of your propeller blades and compare what you see with Figure B to determine if you have a right- or left-hand propeller.

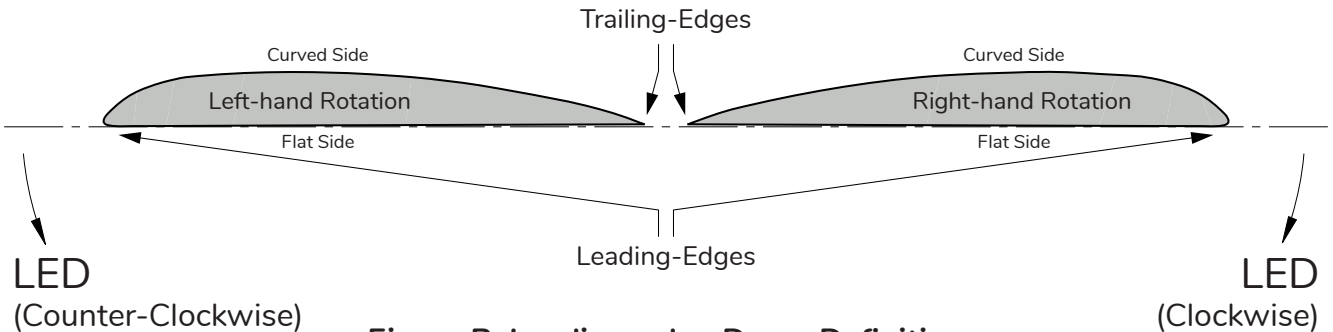

**Figure B: Leading-edge Down Definition**

The leading-edge down (LED) direction can be either clockwise (CW) or counter-clockwise (CCW) depending on whether you have a left-hand-rotation or right-hand-rotation propeller.

## Instructions

1. Rotate each blade in the hub so that the curved side of the blade is pointing forward.
  - “Forward” = the direction your vehicle will travel.
2. Pick one side (left or right) of your vehicle to stand on.
  - Stay on this side when you set the pitch of each blade. You will rotate the entire propeller so that each blade comes around to where you are standing.
3. Spin the propeller so that one of the blades is horizontal to the ground and in front of you.
  - It doesn't have to be perfectly level but be consistent for each blade.
4. Measure the hub angle as shown in Figure C below. With the white clamp facing away from the hub, hold the protractor against the hub and rotate the center wheel until the bubble is level. Make note of which outer scale mark the zero on the inner scale aligns with, that is your hub angle.
  - There are multiple zeros on the inner scale, pick one to use.



9. Clamp the protractor to the blade tip by tightening the wing nuts.
  - The white clamp should be on the curved-side of the blade.
10. Pull out (away from the hub) on the blade to seat the blade root into the hub.
11. Rotate the blade in the hub until the bubble on the protractor is level.
12. Partially tighten the propeller clamping bolts for the blade in front of you.
  - Use a criss-cross pattern. Double check the bubble is still level while/after tightening.
13. Remove the protractor from the blade. Do not loosen the lock knob.
14. Rotate the propeller so that the next blade comes around and becomes horizontal on the side of the vehicle where you've chosen to stand.
15. Repeat steps 9-13 for each blade.
16. Torque the blade clamping-bolts to the proper specifications in 2-ft-lb increments.
17. Check each blade pitch again to ensure the pitch didn't change during torquing.
18. Torque the propeller mounting-bolts to proper specifications in 5-ft-lb increments.

### Example: Tractor, Standing on Left Side, Left-hand Rotation Blades

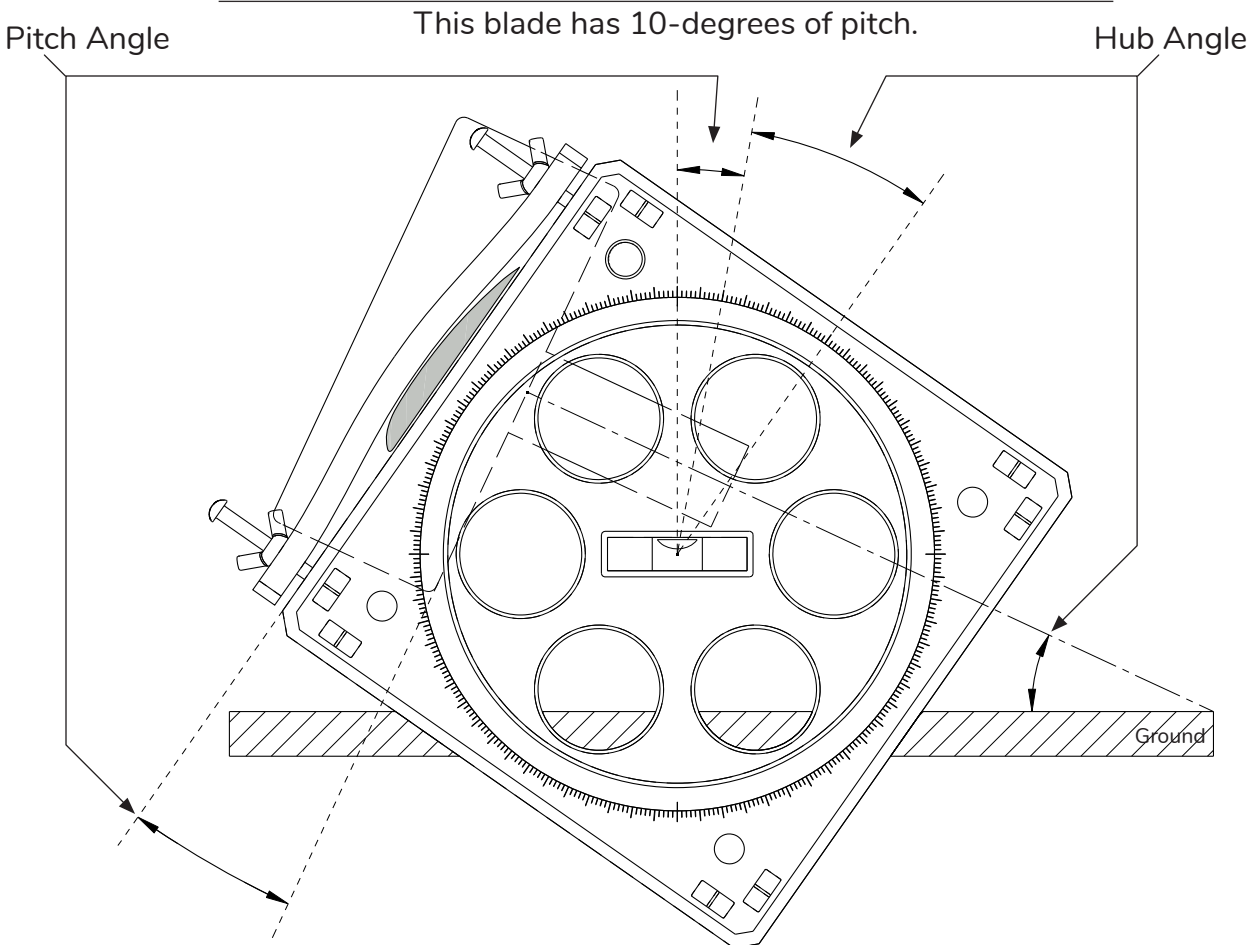

**Figure D: 10-deg Example**

## Stoneguard Leading-edge Tape

---

1. If needed, clean the leading-edge of the blade with a rag and denatured alcohol. DO NOT use a cleaner stronger than denatured alcohol as this will remove the flat black lacquer paint finish and alter prop balance.
2. Remove the paper backing from the Stoneguard tape.
3. Carefully position the tape on the flat side of the blade, starting in 1/16-in from the tip applying half of the width of the tape on the flat side of the blade.
4. Press the tape flat starting at the leading-edge and working out.
5. If you capture an air bubble under the tape that cannot be worked out, use a pin to poke in the center of the bubble and roll smooth.

If your propeller does not have nickel leading-edges, use the full 12" piece of Stoneguard tape. If your propeller does have nickel leading-edges then cut the Stoneguard tape into two 6-in pieces and apply on the leading-edge inboard of the nickel.

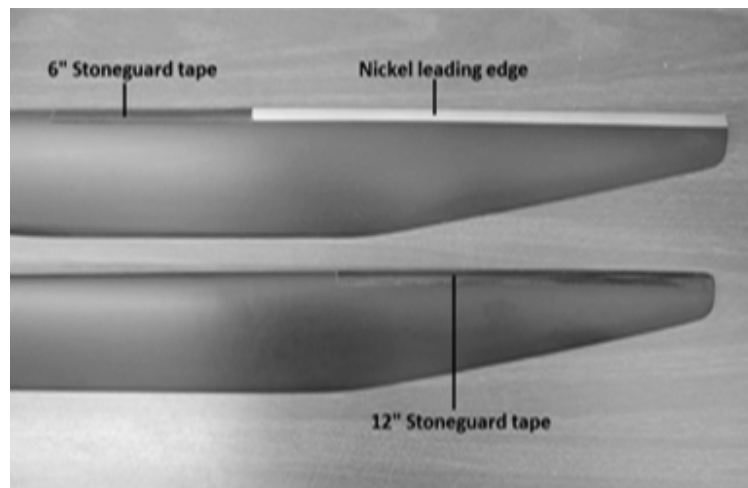

Stoneguard Leading-Edge Tape Installation Options

Leading-edge tape may be replaced by first peeling off the old tape (a heat-gun will help) and then cleaning the area with denatured alcohol.

## Initial Propeller Testing

---

**CAUTION:** RPM MUST NOT EXCEED YOUR POWERPLANT MANUFACTURER'S RECOMMENDED LIMITS.

Proper powerplant setup and operation is beyond the scope of this manual.

1. Check Static RPM: With the brakes set and the vehicle tied down, increase throttle to 100%.
  - Go slowly as to not exceed max powerplant RPM.
  - It is typical for peak RPM while the vehicle is moving to be higher than static RPM. As a general rule, it is recommended to set the static RPM 400-500 RPM under the maximum engine RPM.
2. If static RPM is too high, increase pitch. If static RPM is too low, decrease pitch.
  - It is recommended to make the pitch adjustments in 1-degree increments.
3. Once you have the desired static engine RPM, re-torque all hardware and safety-wire the six propeller mounting bolts (if drilled-head bolts are used).
4. Install the spinner dome (if used).

Your Warp Drive propeller was balanced before it left the factory. It is not necessary to balance the propeller unless repairs have been performed.

**IMPORTANT: THE BOLT TORQUE MUST BE CHECKED AFTER THE FIRST 5 HOURS OF OPERATION AND THEN AGAIN AFTER 50 HOURS OR AT LEAST ONCE A YEAR.**

## Approved Powerplants

---

Rotax 2-stroke (2-Series, 3 Series, 4-Series, 5-Series, 6-Series), Hirth 2-stroke, HKS, Simonini, Cuyuna, Kawasaki, MZ, Polini, Helvenco

**This is an incomplete list. Please contact us to verify your powerplant compatibility.**

Actual weight is determined by mounting-bolt pattern and associated hardware.

| Propeller               | Max Dia | Min Dia | Weight at Max Dia | Propeller Limits           |
|-------------------------|---------|---------|-------------------|----------------------------|
| 4-Blade<br>Standard Tip | 72-in   | 54-in   | 14-lb             | Prop RPM: 3,200<br>HP: 150 |
| 4-Blade<br>Tapered Tip  | 72-in   | 54-in   | 13-lb             | Prop RPM: 3,200<br>HP: 150 |

### **H4 4-Blade Propeller Max Horsepower: 150HP**

Contact Warp Drive if you wish to exceed this specification.

## Repair

---

It is common for a propeller to encounter foreign material that can cause various levels of damage. A pre-flight and post-flight inspection will help to ensure the best propeller performance and longevity. The depth and severity of the damage will determine if the repairs can be performed by an approved LSA repairman, Airframe and Powerplant (A&P) mechanic, Inspection Authorized (IA) mechanic or if the propeller must be returned to the Warp Drive factory for inspection and repair/replacement.

Small nicks and gouges in the carbon fiber up to 1/8-in deep can be filled and repaired by an A&P, IA or approved repairman using a high strength 5 or 10 minute repair epoxy kit (West System, Devcon, etc.) made for composite material repair. Do not sand the damaged area, leave the broken/frayed fibers in place to provide the repair epoxy a better surface to bond with. If damage is more severe, contact Warp Drive for guidance.

- Clean the immediate damaged area with denatured alcohol, acetone or paint thinner. Fill the area with the repair epoxy and cover with masking tape to shape the repair to the original blade shape. Once the epoxy has cured, remove the masking tape, sand the area to match the original blade shape. Re-paint the area with a flat black lacquer spray paint. After the paint has dried, lightly sand the painted area with a medium grade Scotchbrite pad. When re-painting the area keep touch-up paint to a minimum to make re-balancing easier. Re-balance the propeller.
- If your propeller has the inlaid nickel leading-edge protection installed, minor nicks and dents can be repaired by an A&P, IA or approved repairman. However, to properly repair the nickel leading-edge, the entire propeller should be returned to Warp Drive for inspection, repair and re-balancing. At the factory the damaged nickel edges are entirely replaced. All carbon fiber damage underneath the nickel leading-edge is repaired. The entire propeller will then be repainted and rebalanced to factory specifications. If the damage is a minor nick then the area can be lightly sanded smooth. If the damage is a dent that bulges the leading-edge out slightly then the area can be tapped smooth using a hammer and dolly.

Medium grade Scotchbrite can be used to remove foreign material (bugs, grass, dirt, oil, etc...) from the propeller. If propeller wear is a concern, contact Warp Drive for guidance.

In the event of a ground strike or major foreign object strike, ALL propeller components must be returned to Warp Drive for inspection and possible repair or replacement. This includes the propeller blades, hub, clamping bolts, mounting bolts, faceplate, spinner (if used) and prop extension (if used).

All other components should be inspected per the manufacturer's recommendation.

## General Inspection

---

There is no hour limit for Warp Drive propellers. Pre-flight and post-flight inspections should be performed to ensure the overall condition of the propeller and airworthiness. Any service performed on the propeller must be documented in the Propeller Logbook (see below). A visual inspection is critical to ensuring your propeller is airworthy.

1. If you see any changes in the surface such as roughness, cracks, bubbling or discoloration, DO NOT operate your propeller.
2. Check the hub during annual inspections and after any impact. The hub should be checked for cracks, corrosion, or damage of any kind. DO NOT operate your propeller if any of these conditions exist. If in doubt, contact Warp Drive for guidance.
3. All hardware should be re-torqued after the first 5 hours of use, then 50 hours or at annual inspections. If the hardware has been over-torqued or loosened and re-torqued and no longer holds torque, then it needs to be replaced.
4. If you feel vibration when running your propeller, check the pitch of the blades, check the torque of the clamping and mounting hardware. The propeller has been statically balanced at the factory. If you have dynamic propeller balancing available, it is a great method for removing vibration in the entire rotating assembly.

**OPTIONAL:** Applying products such as automotive wax or ArmorAll® will help protect the surface finish, prevent foreign material from sticking, and will aid when cleaning the propeller blades.

## Disassembly Inspection

---

Disassembly inspections should be done annually.

Completely disassemble the propeller and inspect each of the following for damage and:

Spinner: Cracks near all holes.

Bolts: Deformation or corrosion.

Propeller Blades: Deformation, wear, and cracks. Inspect the entire length of each blade looking for any leading-edge damage, fractures or finish wear. If any minor repairs are necessary follow the repair instructions in this manual. If major repairs are necessary return the propeller to the Warp Drive factory for inspection and repair/replacement.

Propeller Hub: Ensure the hub is not bent. Mark the hub halves before disassembly in some way so you know how the two halves were oriented with respect to each other. With the blades removed from the hub, set the two halves back together to check for straightness.

Spin one of the hub halves and check again for a gap or “rocking” between the hub halves.

- For example: if you have a 3-blade hub, spin one of the halves 120 degrees. If you have a 2 blade hub, spin one of the halves 180 degrees.
- Many more accurate methods for inspecting flatness exist. These are beyond the scope of this manual.



